

# Sealeck 40 & 45 Series

WINDOWS AND GLASS

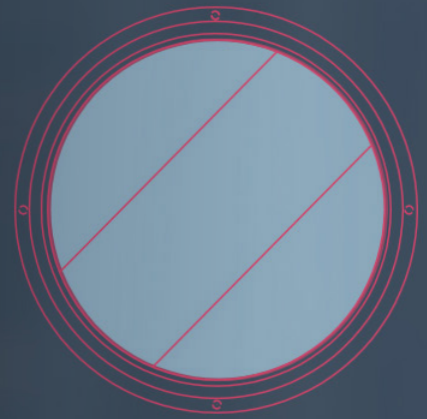
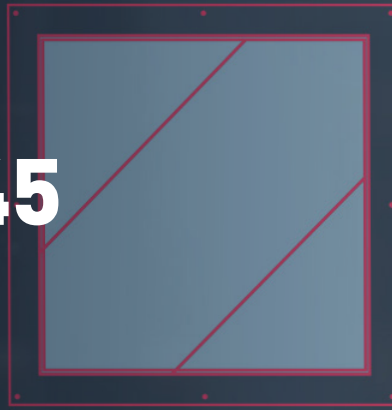

## Rectangular and circular vision panels.

A range of rectangular and circular vision panels which are flush glazed on both sides of the door leaf to suit the requirements of medium to high level bio-containment facilities/ applications, i.e PC3 and PC4.



### SPECIFICATIONS

The vision panel frame is sealed to the door surface and matched with two (one per side) galvabond or galvanneal steel (powder coated), or 304 (316) grade S/S retaining anges.

Countersunk Allen head fixings to non-critical side only, allows clean secure side without

fixings. Optionally fixing holes to non critical side can be provided with plastic plugs/covers.

Vision panel sizes as nominated by client. This vision panel is flush glazed to one side, pre-fitted to the door leaf and glazed with 6.38mm (optional to 12mm) clear laminated safety glass.

Clear view area can be varied to suit customer requirements.

### Sealeck 40 Series

For circular vision openings within PC3 and PC4 applications.

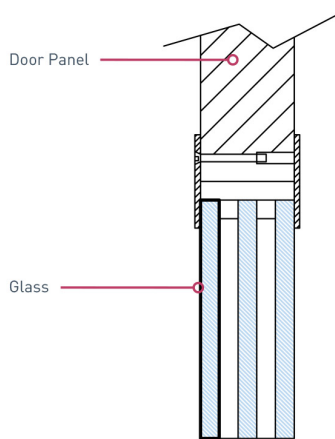

### Sealeck 45 Series

For square and rectangular vision openings within PC3 and PC4 applications.

